



Bolt Selection

The Allart door and window bolt range provides the specifier with an extensive selection of bolts to suit most requirements.

Allart bolts are designed to cater for both commercial and domestic applications offering style and elegance without compromising security owing to their substantial design. The range of finishes available will complement any interior scheme.

Whenever there is a need for fine quality bolts – Allarts have the answer.

Surface Bolts . . . 47 Flush Bolts . . . 48-49 Floor Sockets . . . 49 Espagnolette Bolts . . . 50-51 Barrel Bolts . . . 52
Transom Bolts . . . 52 Indicating Bolts . . . 52 Mortice Rack Bolts . . . 52 Special Products . . . 53

BOLTS – SURFACE MOUNTED

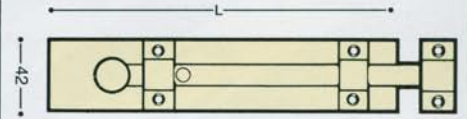

0445 BOLT

- knob slide action
- Lengths L : 200 300
- Shoot size: 13 x 13
- Length of throw: 25

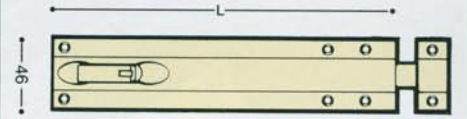

0454 BOLT

- lever action
- Lengths L : 229 305
- Shoot size: 16 x 13
- Length of throw: 16



6473 BOLT

- knob slide action
- Lengths L : 100 150 200
- Shoot size: 10 x 10
- Length of throw: 20

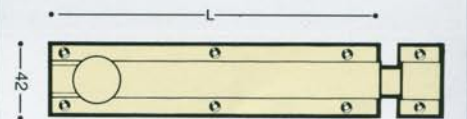

6481 BOLT

- knob slide action
- Lengths L = 200 250 300
- Shoot size : 14 x 8
- Length of throw : 25

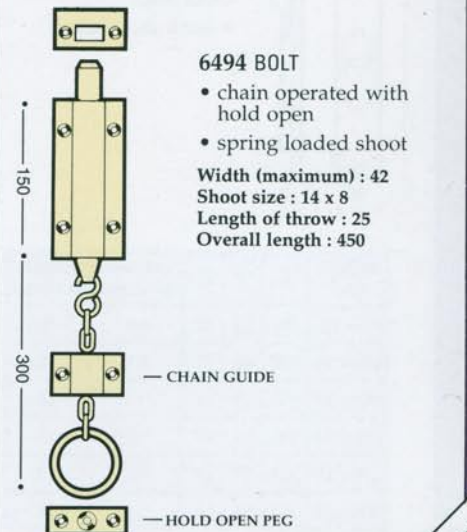

6494 BOLT

- chain operated with hold open
- spring loaded shoot
- Width (maximum) : 42
- Shoot size : 14 x 8
- Length of throw : 25
- Overall length : 450

FRAME FIXING

All Allart Bolts are supplied with frame fixings to suit the most popular application

The following alternatives are available upon request:



Flat Striking Plates



Angled Striking Plates



Easy Clean Sockets

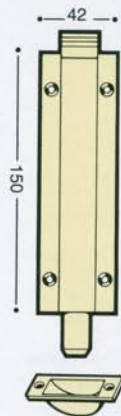

6492 BOLT

- foot operated
- Shoot size : 14 x 8
- Length of throw : 25

BOLTS – FLUSH FITTING

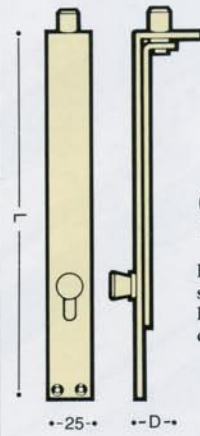

0440 BOLT
 • knob slide action
 lengths L : 152, 229, 305
 shoot size : 11 diameter
 length of throw : 16
 depth of mortice D : 22

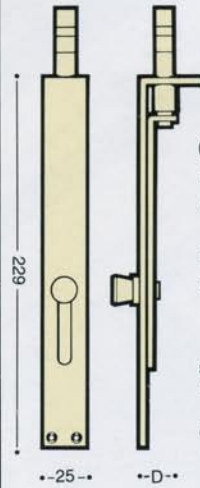

0440ET BOLT
 • knob slide action
 • adjustable length of throw
 • fully retractable shoot
 • length of throw can be easily adjusted on site using a screwdriver
 shoot size : 11 diameter
 Length of throw : 25, 30, 35, 40
 depth of mortice D : 22

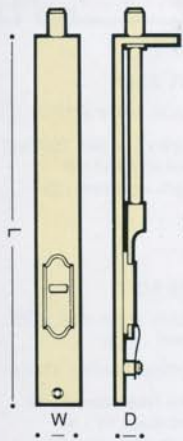

0443 BOLT
 • sunk slide action

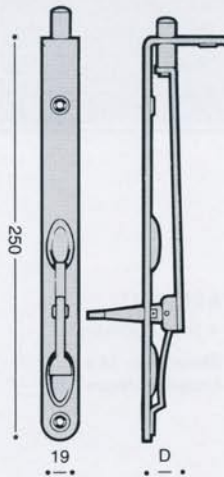

5654 BOLT
 • lever action
 • made from corrosion free stainless steel
 • available in satin or polished finish
 • smooth easy action
 • round ends
 shoot size : 10 diameter
 length of throw : 17
 depth of mortice D : 24

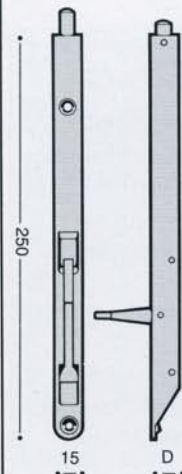

5650 BOLT
 • lever action
 • made from corrosion free stainless steel
 • available in satin or polished finish
 • smooth easy action
 • round ends
 shoot size : 7.5 diameter
 length of throw : 16
 depth of mortice D : 15

order size	L	W	D	shoot diameter	length of throw
76 x 13	76	13	12	6.3	9
102 x 16	102	16	13	6.3	12
152 x 19	152	19	16	9.5	15
152 x 25	152	25	18	11	15
229 x 25	229	25	18	11	15
305 x 25	305	25	18	11	15

BOLTS – FLUSH FITTING

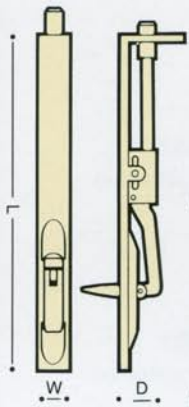

5640 BOLT

- lever action
- high quality coil springing
- smooth easy action
- parallel line of movement

lengths L : 152, 203, 254, 305, 457, 609, 762, 914

widths W : 19, 25

shoot size : 11 diameter

length of throw : 16

depth of mortice D : 22



5640R BOLT

as 5640 above but offering the added benefit of ROUND ENDS

Ideal for:

- joinery shop preparation
- on-site fitting using power routing tools

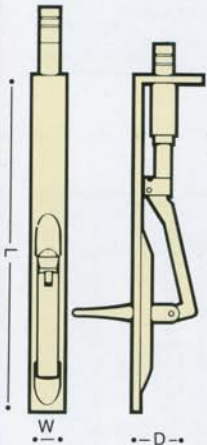

5640ET BOLT

- lever action
- high quality coil springing
- smooth easy action
- adjustable length of throw
- fully retractable shoot
- length of throw can be easily adjusted on-site using a screwdriver

lengths L : 203, 254, 305

widths W : 19, 25

shoot size : 11 diameter

length of throw : 25, 30,

35, 40

depth of mortice D : 38



0620 DUST EXCLUDING FLOOR SOCKET

- spring loaded plunger
- removeable plunger for occasional cleaning and maintenance
- fixing pack for wood and concrete

to suit shoot sizes : 11



0600 DUST EXCLUDING FLOOR SOCKET

- spring loaded plunger
- grooved for mastic fixing in wood or setting in concrete

to suit shoot sizes : 11, 13



0604 EASY CLEAN SOCKET

- shaped for easy cleaning
- fixing pack for wood and concrete

to suit shoot size : 13mm diameter maximum

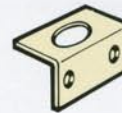

5640 ASP

ANGLE STRIKING PLATE

- designed to strengthen frame fixing where necessary

to suit 11mm shoot



5642 CROSS STRAP

- made from corrosion free stainless steel
- concealed from view no need to match bolt finish
- provides strong top fixing when bolt fitted in the door face

suitable for 5640, 0440 and 0443 flush bolts

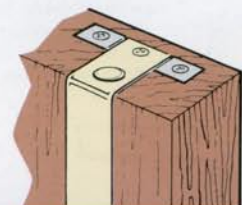

BOLTS – ESPAGNOLETTE

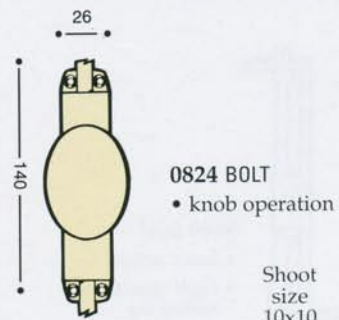
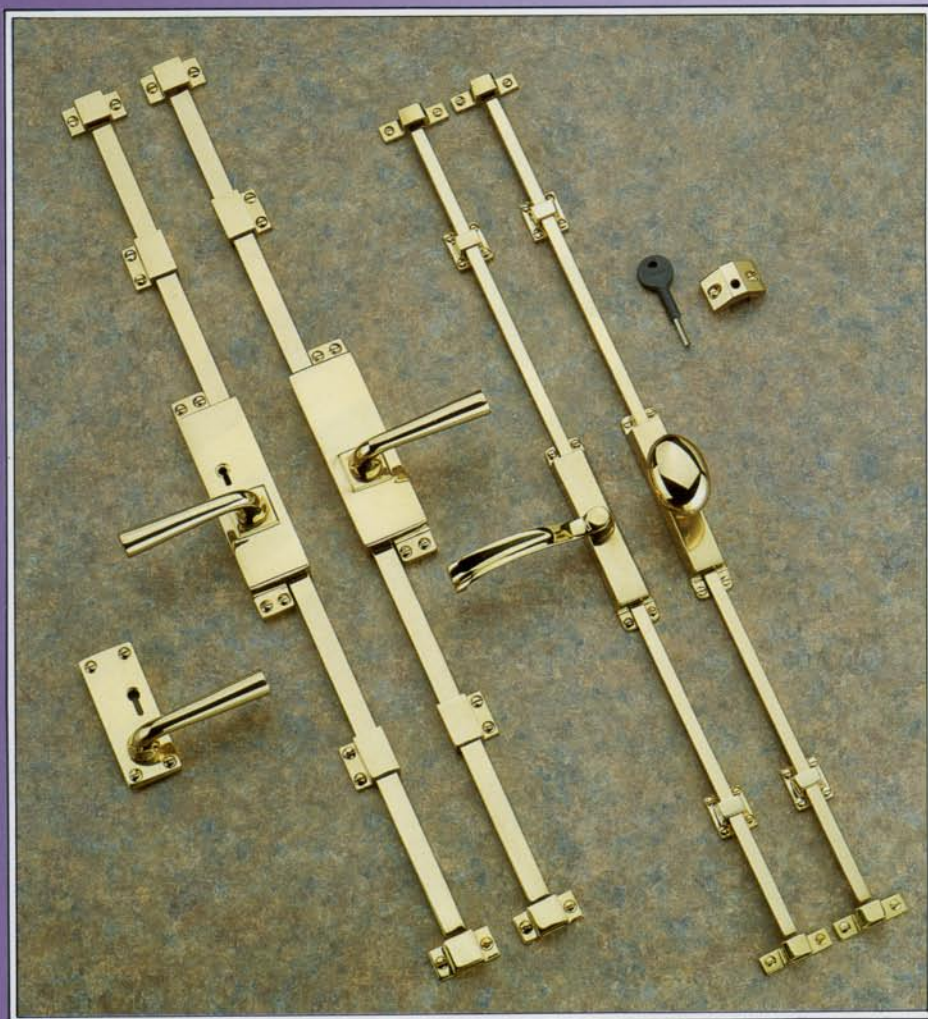

0824 BOLT
• knob operation

Shoot size 10x10

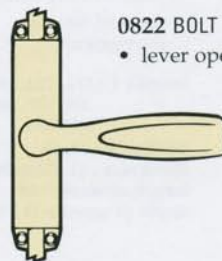

0822 BOLT
• lever operation

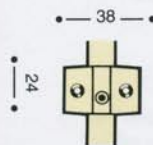

0500 LOCKING BLOCK
• key operation
• adds security
• simple to fit



K500 KEY

Optional extra to fit the following bolts
0822, 0824, 0801, 0803, 0807, 0808, 0810, 0811.

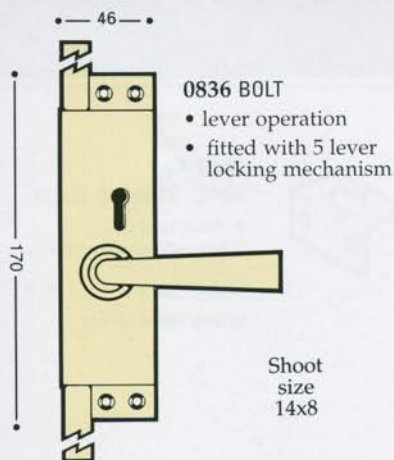

0836 BOLT
• lever operation
• fitted with 5 lever locking mechanism

Shoot size 14x8

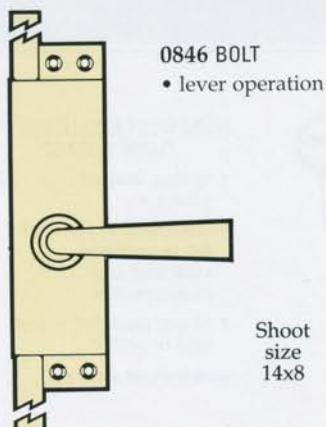

0846 BOLT
• lever operation

Shoot size 14x8

0836 Bolts with 5 lever locking are supplied to differ and complete with two keys. Please specify should locks to pass be required or extra keys

0836WBS LEVER
(optional)

• lever on plate for fitting to the outside face of a door to provide operation and locking from both sides

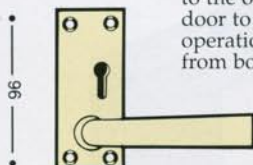

FRAME FIXING

All espagnolette bolts are supplied with both staples and flat striking plates for inward opening doors and angle striking plates for outward opening doors

HOW TO ORDER

1. The bolts on this page are made to suit the handing required.

Suffix catalogue numbers with the hand required eg. 0836RH

2. These bolts are manufactured as standard to suit an opening of 2134mm (84")

Should any other size be required please specify size when ordering eg. 0836RH x 2300mm.

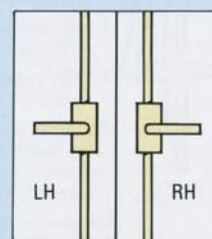

BOLTS – ESPAGNOLETTE

New Design

CASSETTE SYSTEM



- rack & pinion mechanism
- solid brass construction
- reversible for on-site handing
- step-by-step fitting instruction leaflet included

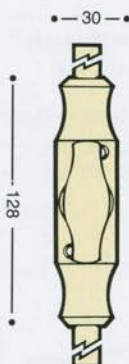

0801 BOLT

- knob operation
- cassette system

Shoot size 13x6

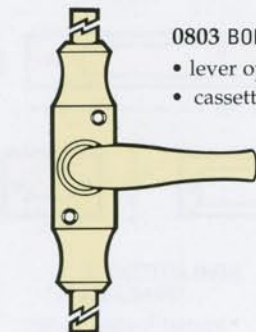

0803 BOLT

- lever operation
- cassette system

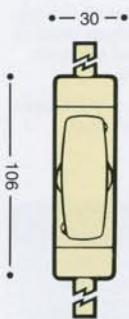

0810 BOLT

- knob operation
- cassette system

Shoot size 10x10

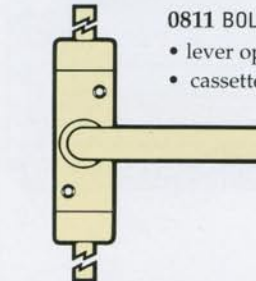

0811 BOLT

- lever operation
- cassette system

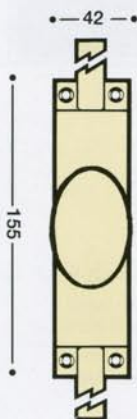

0808 BOLT

- knob operation
- cassette system

Shoot size 14x8

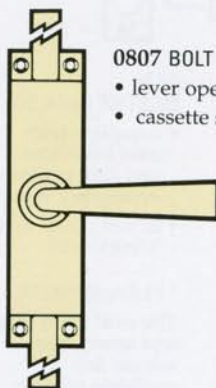

0807 BOLT

- lever operation
- cassette system

FRAME FIXING

All espagnolette bolts are supplied with both staples and flat striking plates for inward opening doors and angle striking plates for outward opening doors

HOW TO ORDER

These bolts are manufactured as standard to suit an opening of 2134mm (84"). Should any other size be required please specify size when ordering eg. 0803 x 2300mm.

Cassette system bolts are reversible therefore handing details are not required.



Bolts are supplied to suit a 2134mm opening. Other lengths are available made to order.

BOLTS – MISCELLANEOUS

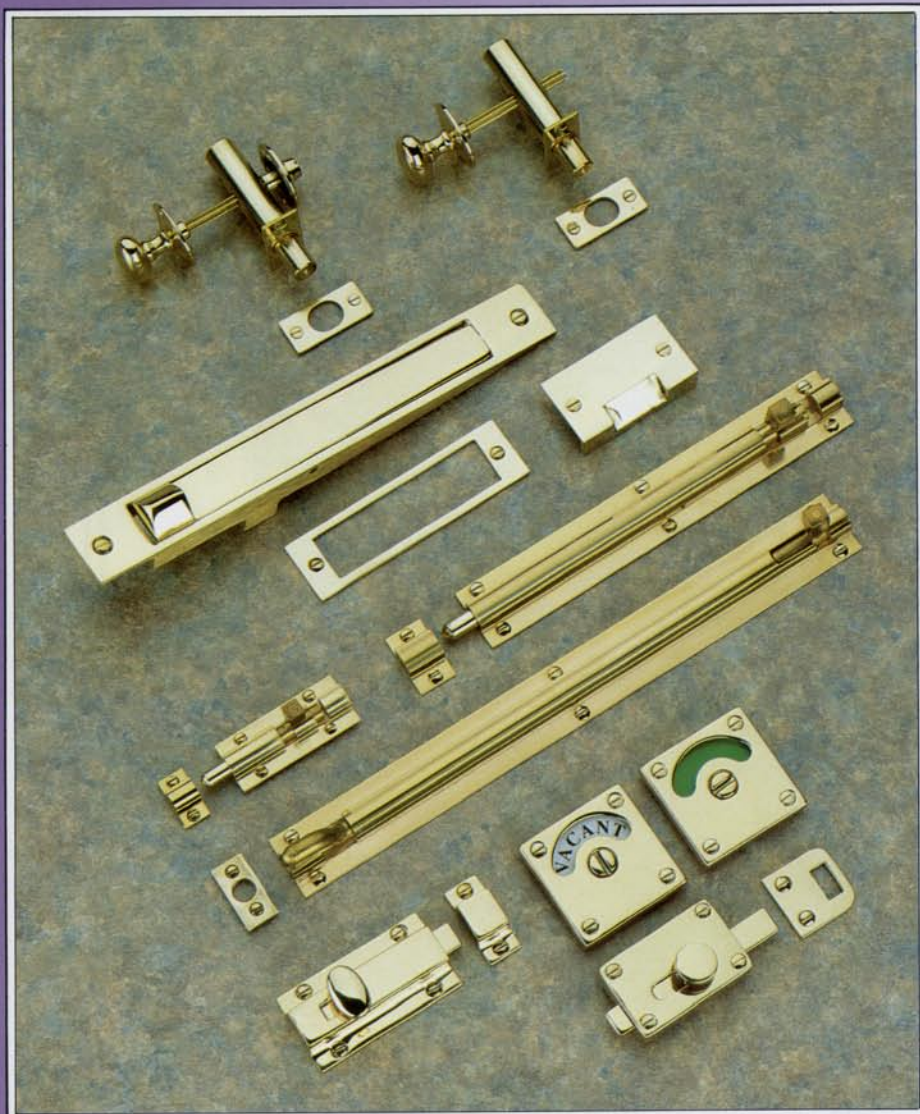

BARREL BOLTS

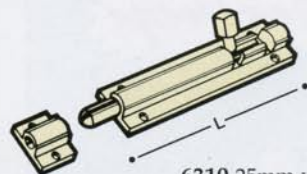

6310 25mm wide straight
lengths L : 50, 64, 76,
102, 152

6320 32mm wide straight
lengths L : 102, 152, 203,
254, 305

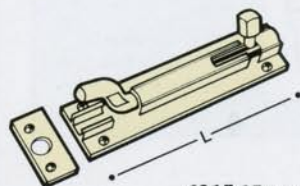

6315 25mm wide necked
lengths L : 76, 102, 152

6325 32mm wide necked
lengths L : 102, 152, 203,
254, 305

TRANSOM BOLT

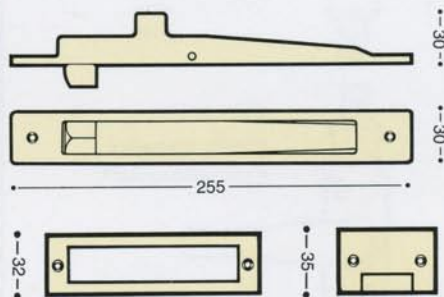

0460 AUTOMATIC TRANSOM BOLT

- spring loaded rocker mechanism
- designed to secure inactive leaf of double door set when used in conjunction with an escape lock
- automatically releases when active leaf opened

AUTOMATIC TRANSOM BOLT *Fitting Instructions*

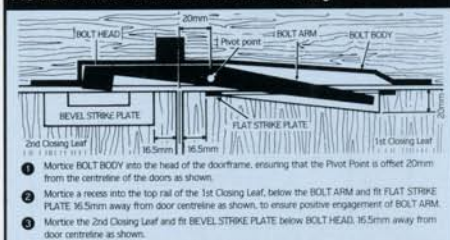

IMPORTANT
It is recommended that all moving parts are lubricated at regular intervals.
PLEASE PASS THIS LEAFLET ON TO THE END USER.

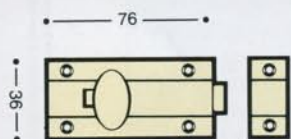

0448 DOOR BOLT
• knob slide action

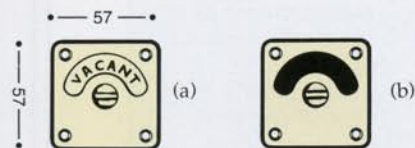
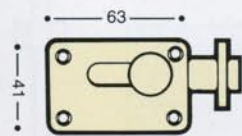

8053 INDICATING BOLT
• bolt throws either side for left or right hand application
• reversible indicating disc (a) vacant/engaged or (b) red/green
• coin operated emergency release

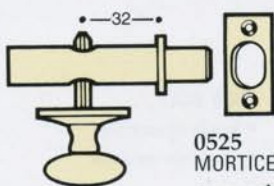

0525 MORTICE RACK BOLT
• complete with oval knob turn
• to suit doors up to 57mm thick

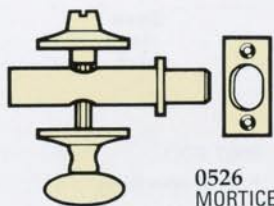

0526 MORTICE RACK BOLT
• complete with oval knob turn and coin operated emergency release
• to suit doors up to 57mm thick

*** PLEASE NOTE**
The oval knob turn and emergency release are available without the mortice rack bolt see page 31 for details.



Our Special Product Service offers adaptations to standard products, special surface finishes, and the manufacture of bespoke designs.

Our Design Department, utilizing sophisticated Computer Aided Design equipment, has the capabilities, knowledge and experience to undertake all aspects of product design and development.

Please contact our Sales Department who will be pleased to provide a quotation against your requirements, with drawings and prototypes available upon request.



F R A N K A L L A R T

Frank Allart & Company Ltd

15/35 Great Tindal Street, Ladywood, Birmingham, B16 8DR, UK.

Tel: 0121- 410 6000 Fax: 0121- 410 6066

International · Tel: +44 (0)121- 410 6000 Fax: +44 (0)121- 410 6066

e-mail: sales@allart.co.uk Web Site: www.allart.co.uk

